

JCM 412 Fabricated Carbon Steel Tapping Sleeves

Built-in benefits make these heavy fabricated steel sleeves increasingly popular for making larger taps on all types of pipe. By placing the design emphasis on eliminating problems inherent with older pipe and field installations, JCM 412 Tapping Sleeves have taken the complexity out of tapping larger pipe.

Built in range assures proper fit on more than one class of pipe - reducing inventory requirements and the chance of not having the right size sleeve.

Ease of assembly eliminates extra equipment, time and specially trained personnel.

Ready availability means taps can be made without long delays - even taps on special sizes of pipe - or services requiring high pressure flanges.

Direct reinforcement of the pipe by the sleeve eliminates flexing or deflection of pipe opposite the tap. Less weight than heavy cast iron sleeves reduces the load on the pipe.

Most important, **JCM 412 Tapping Sleeves assure a safe dependable tap**. A large gasket cross section provides a positive initial seal which increases with increases in line pressure.

Alignment recess for aligning sleeve and tapping valve.

Corrosion resistant, high strength low alloy bolts and nuts. Optional Stainless Steel.

Test Plug 3/4" NPT (stainless steel in the Epoxy Coated tapping sleeve).

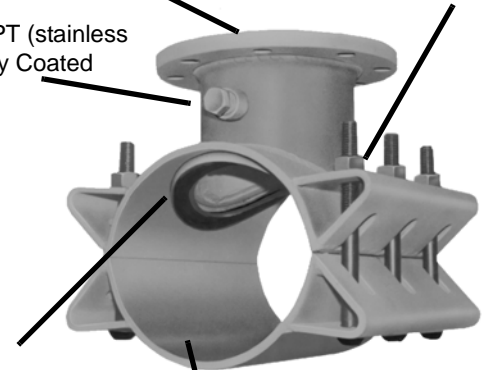

Broad cross section gasket set in retaining cavity.

Heavy steel sleeve with built-in range reinforces pipe - eliminates deflection possibility.

MATERIAL SPECIFICATIONS - JCM 412 FABRICATED TAPPING SLEEVE

BODY: ASTM 283 Grade C or ASTM A-36 Steel

BOLTS: Corrosion Resistant, high strength low alloy (AWWA C-111, ANSI A21.11). Optional Stainless Steel 18-8 Type 304.

FLANGE: AWWA C207 Class D, ANSI 150lb. Drilling, recessed for tapping valve MSS-SP60. Other flanges and outlets available upon request.

GASKET: Compounded for use with water, salt solutions, mild acids and bases.

FINISH: Heavy coat of corrosion resistant metal primer. Optional Fusion Epoxy Coating available.

SERVICE

RATING: 4" to 12" Outlets: 175 PSI. Higher service rating available for specific applications and sizes.

JCM Industries Tapping Sleeves meet or exceed the ANSI/AWWA C-223 and the MSS-SP 124 Standards as applicable.

412 TAPPING SLEEVE DIMENSIONS

Flange Size*	A	B	C	D	E	F
3	12	5	4-1/32	3-1/2	6	3/4
4	12	5	5-1/32	4-1/2	6	3/4
6	12	5	7-1/32	*6-1/2	6	3/4
8	16	5-1/8	9-1/32	8-1/8	8	3/4
10	20	5-1/2	11-1/16	10-1/4	10	3/4
12	24	5-3/4	13-1/16	12-1/4	12	3/4

For outlets 14" and larger the manufacturer of the tapping valve must be specified to assure proper alignment recess dimension.

Size on size tapping sleeve requires 1/2" undersize cutter to assure proper cutter clearance and complete severance of the coupon.

*On nominal pipe size 7.45 and smaller dimension D is 6-1/8".

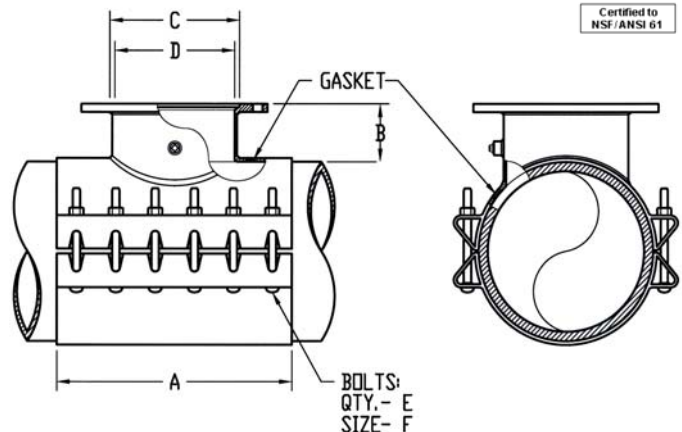

JCM 412 Fabricated Carbon Steel Tapping Sleeves

NOM. PIPE SIZE (IN.)	SLEEVE O.D. RANGE (IN.)	SLEEVE NUMBER X ANY OUTLET	OUTLET SIZES AVAILABLE	APPR. WT. EACH (LBS.)
6	6.63 (SEE 422)			
	6.83 - 7.16	412-0690	X 3	74
	7.05 - 7.40	412-0720	X 4	76
	7.40 - 7.73	412-0745	X 6	82
8	8.63 (SEE 422)			
	8.98 - 9.37	412-0905	X 3	83
	9.27 - 9.69	412-0940	X 4	85
				X 6
			X 8	118
10	9.83 - 10.25*	412-1000	X 3	90
	10.64 - 10.86	412-1075	X 4	92
	11.03 - 11.47	412-1110	X 6	96
	11.36 - 11.80	412-1140	X 8	125
	11.76 - 12.24	412-1200	X 10	168
12	12.62 - 12.88	412-1275	X 3	98
	13.13 - 13.60	412-1320	X 4	100
	13.60 - 14.09	412-1392	X 6	104
	14.08 - 14.56	412-1420	X 8	140
				X 10
			X 12	216
14	14.59 - 15.08	412-1475	X 3	113
	15.23 - 15.80	412-1530	X 4	115
	15.73 - 16.22	412-1600	X 6	116
	16.30 - 16.73	412-1650	X 8	150
				X 10
			X 12	220
16	16.74 - 17.26	412-1684	X 3	113
	17.33 - 17.87	412-1740	X 4	115
	17.88 - 18.43	412-1800	X 6	120
	18.62 - 19.19	412-1875	X 8	162
				X 10
			X 12	230
18	18.87 - 19.45	412-1920	X 3	120
	19.41 - 20.01	412-1950	X 4	122
	20.00 - 20.60	412-2000	X 6	126
	20.29 - 20.94	412-2050	X 8	180
	20.93 - 21.57	412-2130	X 10	240
			X 12	245
20	21.51 - 22.15	412-2160	X 3	131
	22.16 - 22.81	412-2254	X 4	133
	22.78 - 23.45	412-2294	X 6	140
	23.46 - 24.16	412-2400	X 8	185
	24.15 - 24.85	412-2450	X 10	245
	24.82 - 25.52	412-2502	X 12	255
24	25.71 - 26.41	412-2580	X 3	143
	26.55 - 27.25	412-2715	X 4	143
	27.26 - 27.96	412-2746	X 6	160
	28.14 - 28.84	412-2834	X 8	215
				X 10
			X 12	312
30	29.78 - 30.48	412-3000	X 3	163
	30.48 - 31.18	412-3075	X 4	165
				X 6
	31.52 - 32.22	412-3200	X 8	226
				X 10
			X 12	310

*These sizes not available with size on size outlets.

For size on size outlets a 1/2" undersize shell cutter is required.

Larger Sizes: For outlets 14" and larger, the tapping valve to be used must be specified to assure proper alignment recess dimension.
JCM 412 Tapping Sleeves furnished with test plugs unless otherwise specified.



Certified to NSF/ANSI 61