

## JCM 136 Heavy Duty Stainless Repair Clamp Coupling

The JCM 136 Heavy Duty Stainless Steel Repair Clamp incorporates the corrosion resistance of stainless steel, the full circumferential gasketing of a Universal Clamp Coupling and the triangular bolting configuration of the 432 Stainless Steel Tapping Sleeve to provide a repair clamp coupling with high working pressure capabilities.

**All Stainless Steel Construction** - provides superior corrosion resistance in harsh or acidic environments. The JCM 136 is available fabricated of 304 or 316 stainless steel.

**Heavy Duty Stainless Material** - the JCM 136 has a minimum standard material of 14 gauge certifiable prime material. This strong, yet flexible stainless shell conforms to uneven or unusual pipe surfaces and provides complete compression of the gasket on the pipe wall.

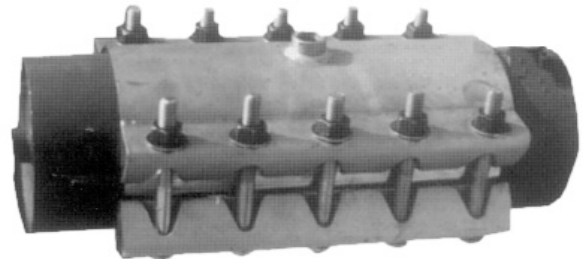

**Tapping Sleeve Bolting System** - with a triangular lug design, allows for pass-through, replaceable bolts. This lug configuration eliminates alignment problems and allows tightening from either side of the pipe.

**Full Circumferential Gasket** - provides a water tight seal on the full circumference of the pipe. The gridded 1/4" thick gasket is of a durometer hardness that allows the rubber to conform to and fill the pits and voids of uneven pipe surfaces.

The JCM 136 Heavy Duty Stainless Repair Clamp is available for all types and sizes of pipe. Options for this fitting includes: 304 Stainless Steel, 316 Stainless Steel, SBR, EPDM or Buna-N Gaskets, 304 Stainless Hardware, 316 Stainless Hardware. Call the JCM Inside Sales Team for product recommendations.

## JCM 136 Heavy Duty Stainless Repair Clamp Coupling

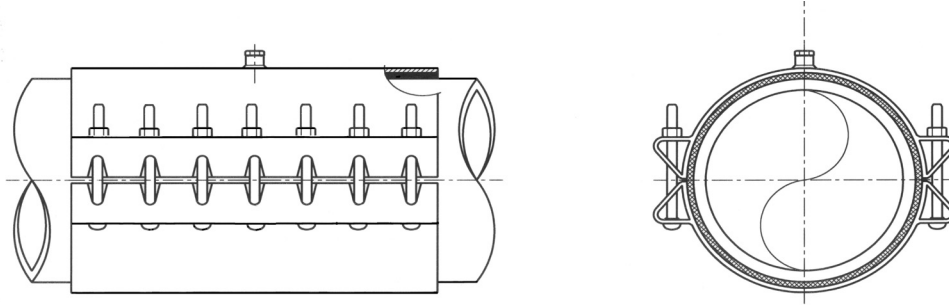

JCM 136 Heavy Duty All Stainless Repair Clamp Coupling - Standard Design

### HOW TO ORDER

For pricing and engineering, the following information must be furnished:

Type of Pipe	Dimension of Damaged Area
Pipe Outside Diameter	Space Limitations
Line Content	Coating Requirements
Line Working Pressure	Optional Material Requirements

### JCM 136 Heavy Duty All Stainless Repair Clamp Coupling - Typical Specifications

All heavy duty repair clamps shall have a minimum material standard of 14 gauge certifiable prime 304 stainless steel construction. Clamps shall have a triangular lug design with bolts on 3" centers. Bolts shall be the pass-through, replaceable type to avoid alignment problems and allow tightening from either side of the pipe. Bolts shall not be integrally welded to the sleeve. Bolts shall be minimum 5/8" 304 stainless steel track head type furnished with permanently lubricated heavy hex nuts and stainless steel washers. The full circumferential gasket shall be molded of synthetic rubber compounded for use with water salt solutions, mild acids, bases and sewage. The gasket shall have a gridded surface, be a full 1/4" thick with 304 stainless steel bridge plates molded flush into the gasket. Clamps shall be fully passivated to insure corrosion resistance. Heavy duty clamps shall be JCM 136 All Stainless Steel Heavy Duty Repair Clamp Coupling or approved equal.

### JCM 136 Heavy Duty All Stainless Repair Clamp Coupling- Material Specifications

<b>BODY:</b>	Stainless Steel 18-8 Type 304. Optional 316 Stainless Steel.
<b>LUGS:</b>	Stainless Steel 18-8 Type 304. Optional 316 Stainless Steel.
<b>BOLTS:</b>	Stainless Steel 18-8 Type 304. Optional 316 Stainless Steel.
<b>GASKET:</b>	The full circumferential gasket shall be molded of synthetic rubber compounded for use with water salt solutions, mild acids, bases and sewage. The gasket shall have a gridded surface, be a full 1/4" thick with 304 stainless steel bridge plates molded flush into the gasket